



31108

CHEVROLET SILVERADO 2500/2500HD/3500
 CHEVROLET SUBURBAN 2500
 GMC SIERRA 2500/2500HD/3500
 GMC YUKON XL 2500
 (VEHICLES WITH AMBER TURN SIGNALS)

CARGO CAPACITY - DO NOT EXCEED 500 LB. OR VEHICLE FRONT GROSS AXLE WEIGHT RATING. (GAWR). RATED FOR 9000- LB. MAX. LINE PULL.
 ***DO NOT EXCEED VEHICLE MANUFACTURER'S RECOMMENDED TOWING CAPACITY ***.

Parts List			
ITEM	QTY	PART NUMBER	DESCRIPTION
1	2	CM-SP33	.250 x 1.50 x 2.00" SQUARE HOLE SPACER
2	2	1/2-13 x 1 3/4	CARRIAGE BOLT
3	4	1/2"	WASHER
4	2	1/2"	CONICAL TOOTHED WASHER
5	2	M12-1.75	HEX FLANGE NUT
6	4	M12-1.75 x 45mm	HEX BOLT
7	2	1/2"	LOCK WASHER
8	2	HFN 1213	HEX FLANGE NUT

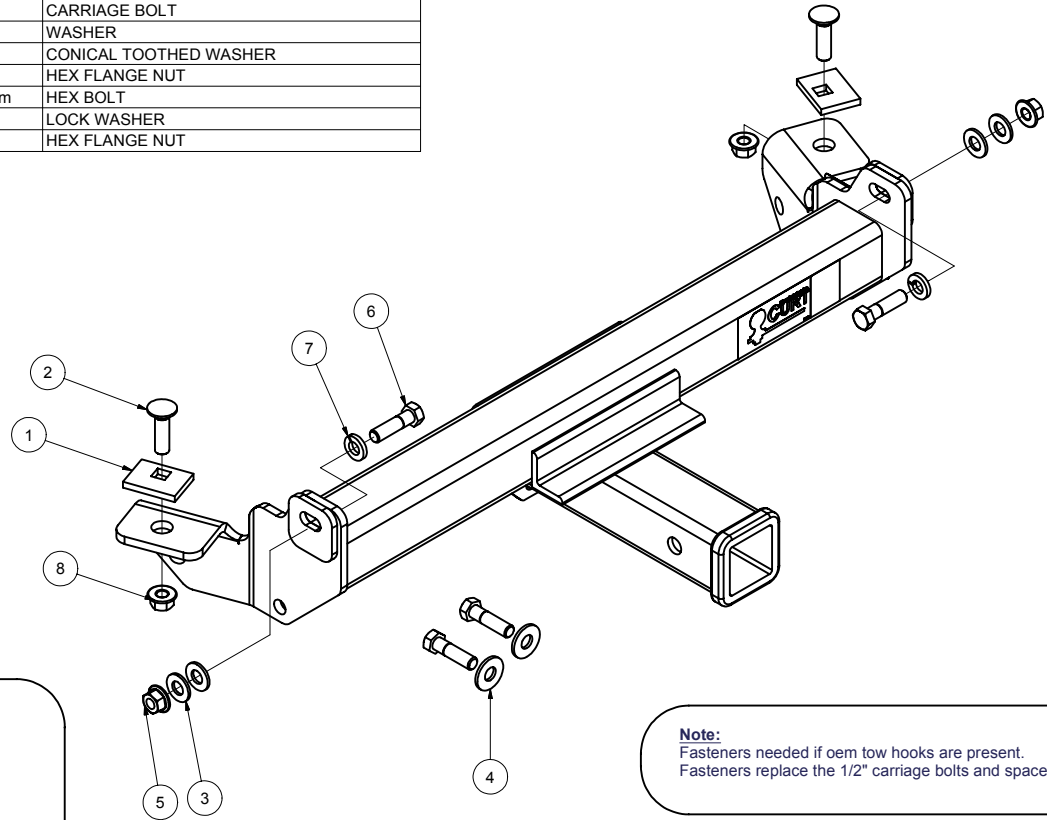

HITCH WEIGHT: 30 LBS.
 INSTALL TIME: 30 MINUTES
 INSTALL NOTES: NO DRILL

Note:
 Fasteners needed if oem tow hooks are present.
 Fasteners replace the 1/2" carriage bolts and spacers.

INSTALLATION STEPS

- 1) If vehicle is equipped with oem tow hook remove tow hook fasteners from inside of frame and bottom of frame and return to vehicle owner.
- 2) Raise hitch into position and install fasteners. Use 1/2" flat washers as spacers between hitch and side of frame if necessary.
- 3) Due to variations in tow hook mounting holes, it may be necessary to enlarge 1/2" holes in hitch to 9/16" holes.

Note: Fascia trimming is optional on 2500 H.D./ 3500 models. Consult vehicle owner before trimming.

- 4) Torque all 1/2" fasteners to 75 LB.-FT. & all M12 fasteners to 75 LB.-FT.

PERIODICALLY CHECK THIS RECEIVER HITCH TO ENSURE THAT ALL FASTENERS ARE TIGHT AND THAT ALL STRUCTURAL COMPONENTS ARE SOUND.

Curt Manufacturing Inc., warrants this product to be free of defects in material or workmanship at the time of retail purchase by the original purchaser. If the product is found to be defective, Curt Manufacturing Inc., may repair or replace the product, at their option, when the product is returned, prepaid, with proof of purchase. Alteration to, misuse of, or improper installation of this product voids the warrant. Curt Manufacturing Inc.'s liability is limited to repair or replacement of products found to be defective, and specifically excludes liability for incidental or consequential loss or damage.



31108

CHEVROLET SILVERADO 2500/2500HD/3500
CHEVROLET SUBURBAN 2500
GMC SIERRA 2500/2500HD/3500
GMC YUKON XL 2500
(VEHICLES WITH AMBER TURN SIGNALS)

CARGO CAPACITY - DO NOT EXCEED 500 LB. OR VEHICLE FRONT GROSS AXLE WEIGHT RATING. (GAWR) 9000- LB. MAX. WINCH LINE PULL.
***DO NOT EXCEED VEHICLE MANUFACTURER'S RECOMMENDED TOWING CAPACITY ***.

FRONT MOUNTED ACCESSORIES

1) Do not exceed front axle Gross Weight Rating (GAWR). Consult owners manual or specification plate located on driver's door frame. Measure gross front axle weight by placing front wheels of loaded vehicle on a scale.

WARNING: Exceeding GAWR may overload the front axle and/or suspension. This could result in **accident, property damage and personal injury.**

- 2) Reposition front mounted license plate if obstructed.
- 3) Do not obstruct vehicle lights.
- 4) Allow free air flow into grille opening.
- 5) Rear wheel traction may be reduced. This could effect handling. Reduce speed and drive with caution.
- 6) Accessories extend front of vehicle. This may reduce approach angle. Use caution when parking and maneuvering.
- 7) Do not obstruct driver view.

VEHICLE RECOVERY AND WINCHING TIPS

1) Use OEM tow hooks, recovery eyes or a clevis mount for attachment of a tow strap or winch cable.

WARNING: NEVER use a ball and/or ball mount as an anchor point for tow strap or winch cable. Severe personal injury or death could result.

- 2) Observe winch manufacturer's recommendations, cautions and warnings.
- 3) Attach return cable to tow hook or recovery eye when using a snatch block (See figure 1).

CAUTION: Do not attach return cable to winch mount. This may overload winch mount and/or front mounted receiver.

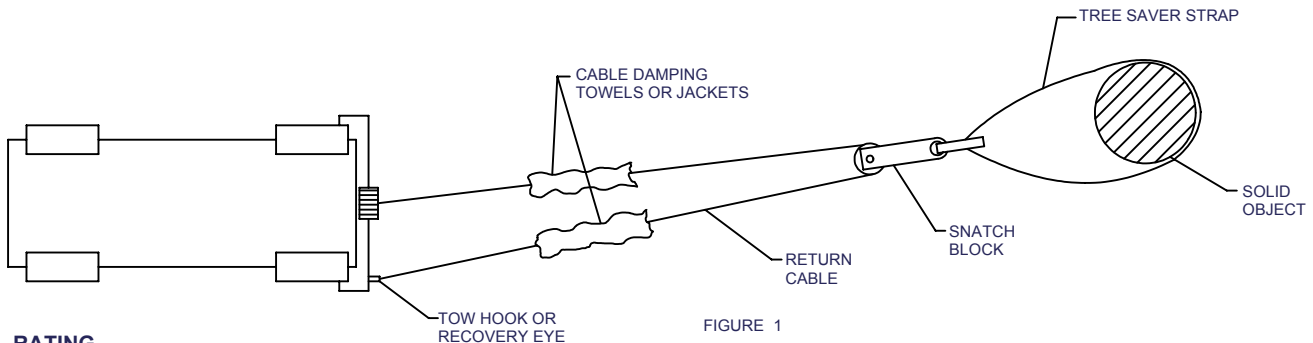

RATING

- For **Maximum** line pull rating, winch cable must not exceed:
- 15 degree angle up or down from horizontal (See Figure 2).
 - 45 degree angle left or right from straight ahead (See Figure 3).

CAUTION: Exceeding the maximum line pull rating may over load winch, winch mount, and/or front mounted receiver.

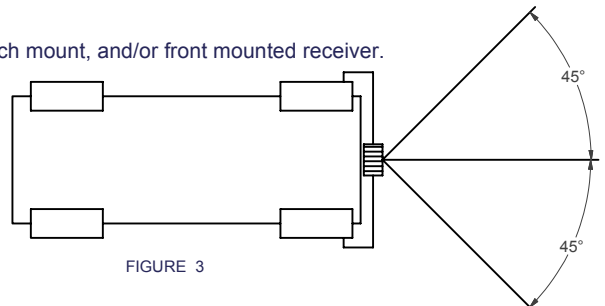
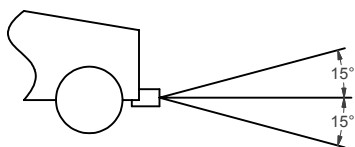

Curt Manufacturing Inc., warrants this product to be free of defects in material or workmanship at the time of retail purchase by the original purchaser. If the product is found to be defective, Curt Manufacturing Inc., may repair or replace the product, at their option, when the product is returned, prepaid, with proof of purchase. Alteration to, misuse of, or improper installation of this product voids the warranty. Curt Manufacturing Inc.'s liability is limited to repair or replacement of products found to be defective, and specifically excludes liability for incidental or consequential loss or damage.