

13326 / 3814AT / RRH13326**DODGE RAM 1500,2500,3500****3/25/2008**

GROSS LOAD CAPACITY WHEN USED AS A WEIGHT CARRYING HITCH: 5,000 LBS. TRAILER WEIGHT & 500 LBS. TONGUE WEIGHT.
 GROSS LOAD CAPACITY WHEN USED AS A WEIGHT DISTRIBUTION HITCH: 10,000 LBS. TRAILER WEIGHT & 1,000 LBS. TONGUE WEIGHT

*****DO NOT EXCEED VEHICLE MANUFACTURER'S RECOMMENDED TOWING CAPACITY.*****

Parts List			
ITEM	QTY	PART NUMBER	DESCRIPTION
1	1	1_2 x 30 FISHWIRE	1/2" x 30" FISHWIRE
2	2	CM-SP6	.250 x 1.00 x 3.00" SQUARE HOLE SPACER
3	2	1/2 - 13 x 2"	CARRIAGE BOLT
4	2	HFN 1213	HEX FLANGE NUT
5	2	5_8 - 11 x 2 FHSCS	FLAT HEAD SOCKET CAP SCREW
6	2	5/8-11	HEX FLANGE NUT
7	1	CM-13326-BP	.625 x 2.00" BACKING PLATE

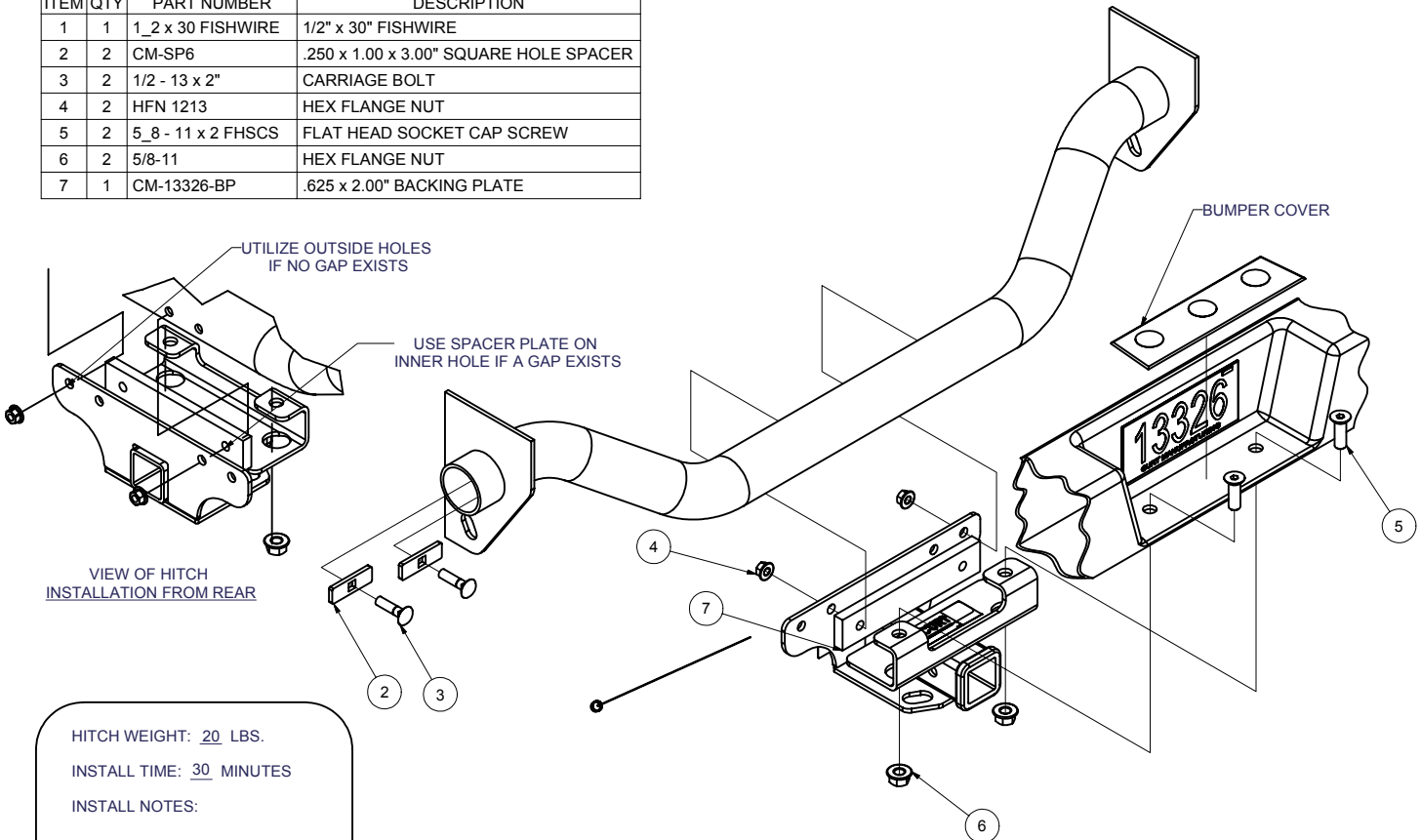

HITCH WEIGHT: 20 LBS.

INSTALL TIME: 30 MINUTES

INSTALL NOTES:

NO DRILLING REQUIRED

INSTALLATION STEPS

- 1) Locate the four plastic locking studs under the bumper which hold the bumper cover to the top of the steel bumper. With a pair of pliers, carefully squeeze these studs together and push them up through the bumper. Use care when removing these studs as to not damage the locking tabs on the studs. From the top, carefully pull the bumper cover up to gain access to the top of the steel bumper. Do not deform the bumper cover when removing it. Underneath the bumper cover there will be two 3/4" diameter holes on either side of the bumper cavity. These holes will be utilized for hitch attachment.
- 2) Place a 5/8" flat head bolt down through each of the outer 3/4" holes in the bumper as shown,
- 3) Carefully position the hitch against the bottom surface of the bumper so that the previously installed bolts drop through the holes in the hitch. Loosely secure using fasteners as shown.
- 4) Using the included fishwire, insert a 1/2" carriage bolt and rectangular backing plate into the end of the round inner bumper beam. Pull the bolts out through the holes in the bumper beam as shown.
NOTE: Check to see if there is a gap between the bumper beam and the hitch mounting plate. If there is a gap, place the spacer plate between the bumper beam and the hitch mounting plate before installation of the attachment fasteners. If there is not a gap, the spacer plate is not used.
- 5) Torque all 5/8" fasteners to 170 lb-ft, and all 1/2" fasteners to 75 lb-ft.

PERIODICALLY CHECK THIS RECEIVER HITCH TO ENSURE THAT ALL FASTENERS ARE TIGHT AND THAT ALL STRUCTURAL COMPONENTS ARE SOUND.

Curt Manufacturing Inc., warrants this product to be free of defects in material and/or workmanship at the time of retail purchase by the original purchaser. If the product is found to be defective, Curt Manufacturing Inc., may repair or replace the product, at their option, when the product is returned, prepaid, with proof of purchase. Alteration to, misuse of, or improper installation of this product voids the warranty. Curt Manufacturing Inc.'s liability is limited to repair or replacement of products found to be defective, and specifically excludes liability for incidental or consequential loss or damage.