

# 13028 / RRH13028

88-91 CHEVY/GMC 4 DR CREW CAB ONLY  
73-06 CHEVY/GMC FULL SIZE CAB & CHASSIS w 34" FRAME  
62-87 CHEVY/GMC ALL FULL SIZE: except 10" bumper

73-79 FORD 250 CREW CAB  
73-06 PICKUP: CAB AND CHASSIS 34" frame width

10/30/2007

GROSS LOAD CAPACITY WHEN USED AS A WEIGHT CARRYING HITCH: 6,000 LBS. TRAILER WEIGHT & 600 LBS. TONGUE WEIGHT.  
GROSS LOAD CAPACITY WHEN USED AS A WEIGHT DISTRIBUTION HITCH: 10,000 LBS. TRAILER WEIGHT & 1,000 LBS. TONGUE WEIGHT

**\*\*\*DO NOT EXCEED VEHICLE MANUFACTURER'S RECOMMENDED TOWING CAPACITY.\*\*\***

Parts List			
ITEM	QTY	PART NUMBER	DESCRIPTION
1	6	1/2 - 13 x 2"	CARRIAGE BOLT
2	6	HFN 1213	HEX FLANGE NUT
3	12	CM-SP1	.250 x 1.50 x 2.00" SQUARE HOLE SPACER

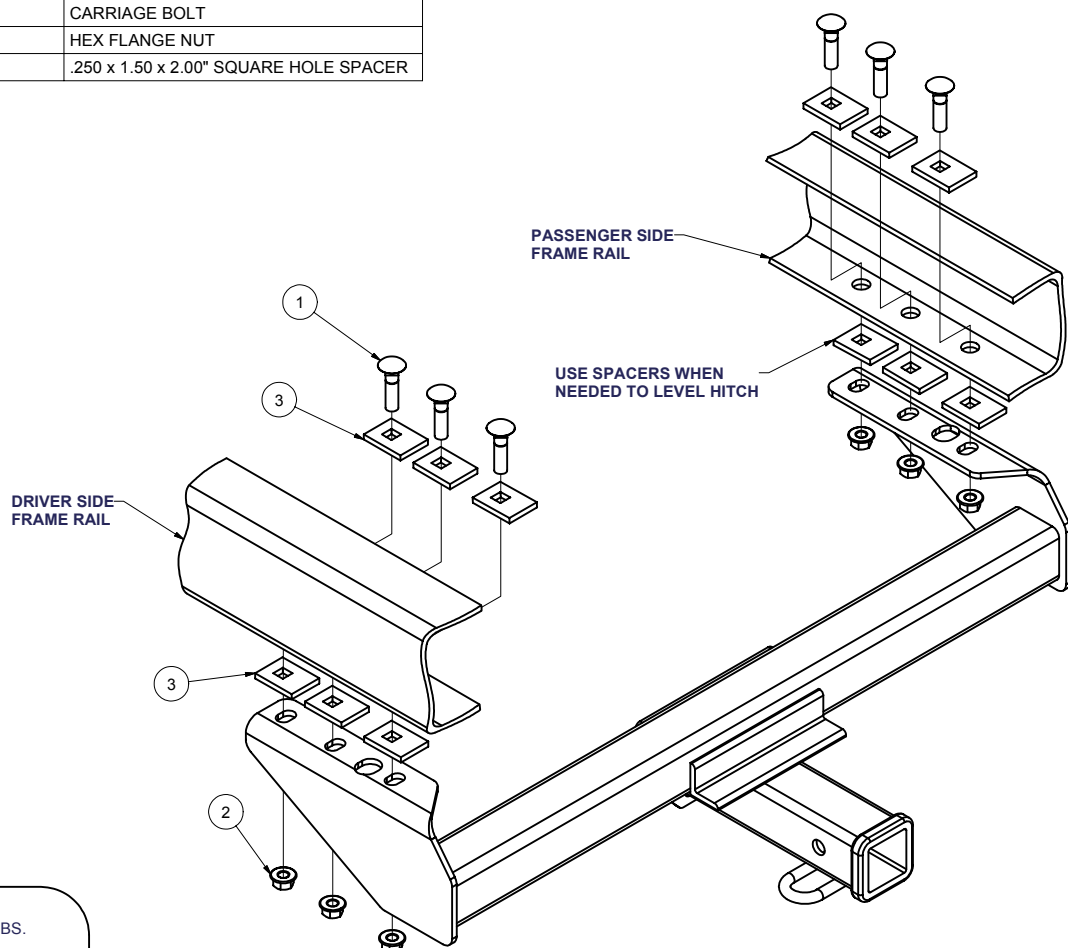

HITCH WEIGHT: 36 LBS.

INSTALL TIME: 45 MINUTES

INSTALL NOTES:

- REMOVE SPARE TIRE
- DRILLING REQUIRED
- RE-INSTALL SPARE TIRE

## INSTALLATION STEPS

- 1) Remove spare tire and rear bolt on tire holder. Clean mounting surface as needed.
- 2) Place spacers between hitch and frame as shown (clamp hitch into position). Using the hitch as a template, mark and drill 1/2" mounting holes. Make sure wires and hoses will not be damaged when drilling.

NOTE: hitch must be positioned so end of receiver tube is flush with back of vehicle.

- 3) Install fasteners as shown above, and remove clamps.
- 4) Torque all 1/2" fasteners to 75 lb-ft.
- 5) Re-install spare tire and removed hardware if possible.

**PERIODICALLY CHECK THIS RECEIVER HITCH TO ENSURE THAT ALL FASTENERS ARE TIGHT AND THAT ALL STRUCTURAL COMPONENTS ARE SOUND.**

Curt Manufacturing Inc., warrants this product to be free of defects in material and/or workmanship at the time of retail purchase by the original purchaser. If the product is found to be defective, Curt Manufacturing Inc., may repair or replace the product, at their option, when the product is returned, prepaid, with proof of purchase. Alteration to, misuse of, or improper installation of this product voids the warranty. Curt Manufacturing Inc.'s liability is limited to repair or replacement of products found to be defective, and specifically excludes liability for incidental or consequential loss or damage.